

**Digital Undercounter
 ecostore HP Concept Refrigerated
 Counter - 4 ½ Drawer without worktop
 (R290)**

ITEM # _____

MODEL # _____

NAME # _____

SIS # _____

AIA # _____

710456 (EK2H7BB)

4x1/2-drawer Refrigerated Counter, -2+10°C, AISI 304 (R290), without work top

Short Form Specification

Item No. _____

AISI 304 stainless steel panels, AISI 430 bottom panel, galvanized back panel. N. 4X1/2 drawers. Built-in refrigeration unit. Operating temperature: -2+10°C. R290 gas in refrigeration circuit.

Main Features

- Combination of doors and drawers to suit varying needs, with the possibility to change the configuration on site.
- Digital control panel.
- Forced air circulation for rapid cooling and an even temperature distribution.
- Refrigerated compartment designed to accept GN 1/1 containers.
- Small footprint to fit even in limited environments.
- Certified safety CE requirements.
- Frontal and easy access to all components in the cooling unit.
- Combination of doors and drawers to suit any configuration needed, with the possibility to change the configuration on site. Right cooling unit available on request.
- Preservation performances and temperature uniformity within the cell guaranteed at 5-HEAVY DUTY (40°C) working conditions according to EN16825:2016 test protocol.
- Hot gas automatic evaporation of defrost water.
- 0mm clearance installation space: tower configuration cooling unit guarantee performance with frontal ventilation only; this unique solution allows installation against the wall or side by side with other appliances, even on the cooling unit side to maximize the use of kitchen space.
- Prearranged to fit RS485 port to facilitate connection to a remote computer and integrated HACCP systems.
- Self closing stainless steel doors (< 90°).
- Anti-tilt runners accept GN 1/1 containers.
- Equipped with forced air circulation system for rapid cooling and temperature distribution within the cell.
- Adjustable temperature range from -2 °C to +10 °C to suit meat, fish and dairy storage requirements.
- Automatic evaporation of defrost water.
- Digital white-digit display with internal temperature display and setting, manual activation of defrost cycle and turbo frost cycle (to rapidly cool warm loads).
- Tropicalized unit.

Construction

- Access to all components from the front.
- Built-in compressor to suit operating conditions.
- Developed and produced in ISO 9001 and ISO 14001 certified factory.
- Fault code display.
- Interior base with rounded corners, pressed from a single sheet.
- Internal and external doors, front, back and side panels in AISI 304 Stainless steel.
- Mounted on Stainless steel adjustable legs to give 150 mm clearance for ease of cleaning.
- Mounted on stainless steel feet to give 150 mm (-5/+50 mm) clearance for ease of cleaning the floor.
- Rounded internal corners for ease of cleaning.

APPROVAL: _____

- Pre-arranged for drain-pipe.
- Built-in refrigeration unit.
- Ease of cleaning and high hygiene standards thanks to the rounded internal corners, the easily removable runners, grids and air conveyors.
- Internal structure with 15 charging positions (3 cm pitch) available to host GN 1/1 grids, ensuring higher net capacity and a greater storage space.
- Extractable cooling unit to facilitate maintenance.
- IP21 protection index.
- Internal and external doors, front and side panels and removable worktop in AISI 304 Stainless steel.
- External bottom panel in stainless steel.
- External back panel in galvanized steel.
- Excellent space optimisation thanks to the compact dimensions.
- Internal dimension of the drawers:
 - models with 2 1/2 drawers: 1st drawer (top drawer) 203x302x521 / 2nd drawer 223x302x521 (HxWxD)
 - models with 3 1/3 drawers: 1st drawer (top drawer) 98x302x521 / 2nd and 3rd drawers 118x302x521 (HxWxD)
 - models with 1/3+2/3 drawers: 1st drawer (top drawer) 98x302x521 / 2nd drawer 333x302x521 (HxWxD)
- Mounted on 150 mm adjustable feet.
- 304 AISI stainless steel internal and external doors, front and side panels. Evaporator in aluminium.
- High-density expanded polyurethane foam 50 mm in thickness with cyclopentane injection.

Sustainability



- Removable triple-chamber balloon magnetic gasket to improve insulation and reduce energy consumption and ease of cleaning.
- Fitted with 90 mm thickness of cyclopentane insulation for best insulating performance (thermal conductivity: 0,020 W/m*K) and lowest environmental impact (GWP=3).

Optional Accessories

- | | | |
|--|------------|--------------------------|
| • 2x½ drawer kit for refrigerated counters | PNC 881058 | <input type="checkbox"/> |
| • 3x1/3 drawer kit for refrigerated counters | PNC 881059 | <input type="checkbox"/> |
| • 1/3 and 2/3 bottle drawer kit for refrigerated counters | PNC 881071 | <input type="checkbox"/> |
| • 1/1GN grey rilsan grid for refrigerated counters | PNC 881107 | <input type="checkbox"/> |
| • 2 side runners for 1/1 GN ecostore refrigerated counters | PNC 881108 | <input type="checkbox"/> |
| • Kit 1/1 grey rilsan grid and 2 side runners for refrigerated counters | PNC 881109 | <input type="checkbox"/> |
| • 1/1 GN plastic container, H=65 mm | PNC 881110 | <input type="checkbox"/> |
| • 1/1 GN plastic container, H=100 mm | PNC 881111 | <input type="checkbox"/> |
| • 1/1 GN plastic container, H=150 mm | PNC 881112 | <input type="checkbox"/> |
| • Kit 4 wheels, H=100 mm (2 with brakes) for refrigerated counters | PNC 881191 | <input type="checkbox"/> |
| • Kit 4 wheels, H=150 mm (2 with brakes) for 2&3 compartment refrigerated counters | PNC 881193 | <input type="checkbox"/> |
| • Lock for refrigerator/freezer counters with 2 compartments - h700mm (can be used in kit for Marine conversion) | PNC 881242 | <input type="checkbox"/> |

Front

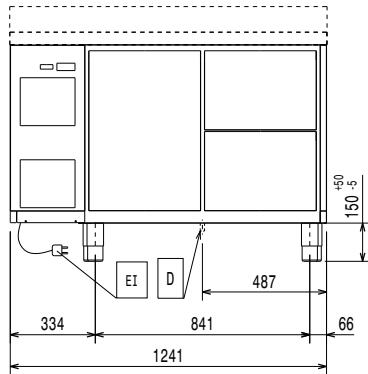

Side

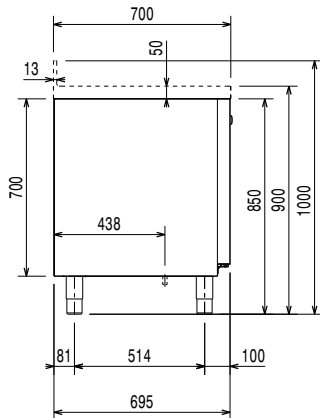

EI = Electrical inlet (power)

Top

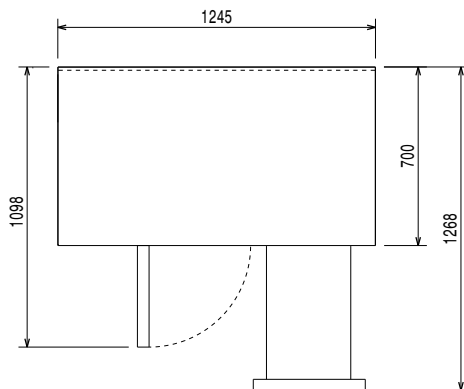
Electric

Supply voltage:	220-240 V/1 ph/50 Hz
Electrical power, max:	0.22 kW

Key Information:

Net Volume:	124 lt
N° of doors:	
External dimensions, Width:	1241 mm
External dimensions, Depth:	700 mm
External dimensions, Height:	850 mm
Internal Dimensions, Width:	798 mm
Internal Dimensions, Depth:	560 mm
Internal Dimensions, Height:	550 mm
Net weight:	96 kg
Shipping volume:	1.04 m ³
Depth with doors open:	1110 mm
Gross capacity:	290 lt

Refrigeration Data

Control type:	
Min/Max internal humidity:	40/85
Operating temperature min.:	-2 °C
Operating temperature max.:	10 °C
Compressor power:	0.25 hp
Operating mode:	Ventilated
Insulation:	90 mm (Cyclopentane)

ISO Certificates

ISO Standards:	ISO 9001; ISO 14001; ISO 45001; ISO 50001
----------------	---

Sustainability

Refrigerant type:	R290
GWP Index:	3
Refrigeration power:	358 W
Refrigerant weight (unit 1):	45 g
Energy Class (EU Reg. 2015/1094):	A
Yearly and daily energy consumption (EU Reg. 2015/1094):	525kWh/year - 1kWh/24h
Climate class (EU Reg. 2015/1094):	Normal duty (cl.4)
Energy Efficiency Index-EEI (EU Reg. 2015/1094):	24,92

EU energy labelling from 1st July 2016

The European energy labelling scheme for professional refrigerators and freezers is based on requirements setting Minimum Energy Performance standards for commercial refrigeration cabinets sold within the EU.

These requirements are designed to drive energy efficiency and environmentally friendly approach for professionals. The European energy labelling scheme will apply to all manufacturers and importers who sell and market products within the EU and it is mandatory across Europe. Important: all products which consume energy above the minimum level will not be able to be sold within the EU from 1 July 2016.

SI 2020 No. 1528.

Important: all products which consume energy above the minimum level will not be able to be sold within the EU from 1 July 2016.

